

Technical Information

- CV** Check Valves
- SH** Shuttle Valves
- LM** Load/Motor Controls
- FC** Flow Controls
- PC** Pressure Controls
- LE** Logic Elements
- DC** Directional Controls
- MV** Manual Valves
- SV** Solenoid Valves
- PV** Proportional Valves
- CE** Coils & Electronics
- BC** Bore/Bores & Cavities
- TD** Technical Data

General Description

2-Way, 2 Position, Normally Closed Poppet Valve. For additional information see Technical Tips on pages SV1-SV6.

Features

- High flow capacity with reduced space requirements
- One piece cartridge housing ensures internal concentricity
- Coil: Waterproof, hermetically sealed, requires no O'Rings; Coil is interchangeable with 02 and 06 series poppet valves; Symmetrical coil can be reversed without affecting performance.
- All external parts zinc plated

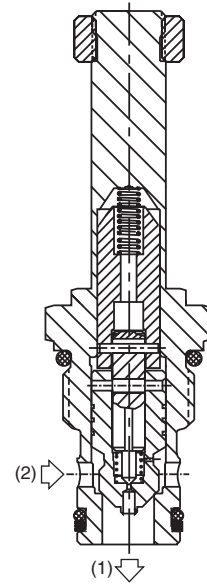
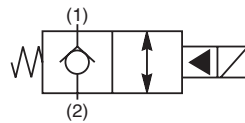

Specifications

Rated Flow (At 70 PSI ΔP)	75 LPM (20 GPM)
Maximum Inlet Pressure	350 Bar (5000 PSI)
Leakage at 150 SSU (32 cSt)	5 drops/min. (.33 cc/min.)
Minimum Operating Voltage	85% of rated voltage at 20°C (72°F).
Response Time	Open 80 ms Close 70 ms
Cartridge Material	All parts steel. All operating parts hardened steel.
Operating Temp. Range/Seals	-40°C to +93.3°C (Nitrile) (-40°F to +200°F) -31.7°C to +121.1°C (Fluorocarbon) (-25°F to +250°F)
Fluid Compatibility/Viscosity	Mineral-based or synthetic with lubricating properties at viscosities of 45 to 2000 SSU (6 to 420 cSt)
Filtration	ISO Code 16/13, SAE Class 4 or better
Approx. Weight	.15 kg (.34 lbs.)
Cavity	C10-2 (See BC Section for more details)

Performance Curve

Pressure Drop vs. Flow (Through cartridge only)

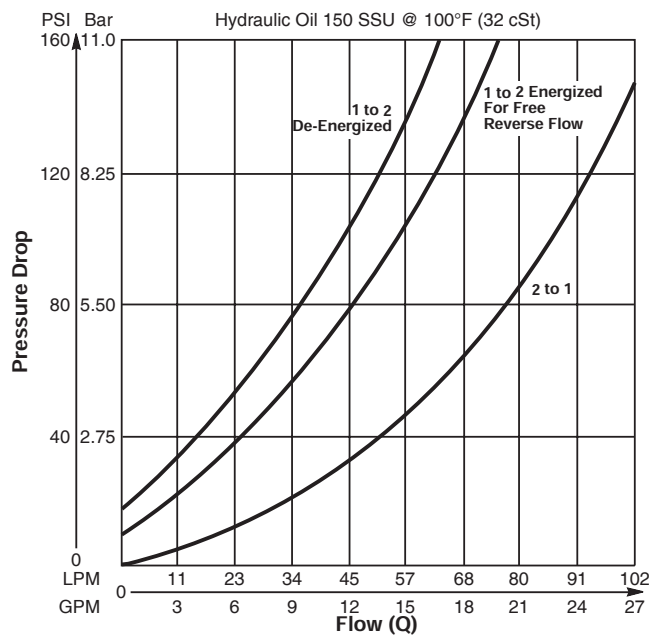

Technical Information

Dimensions Millimeters (Inches)

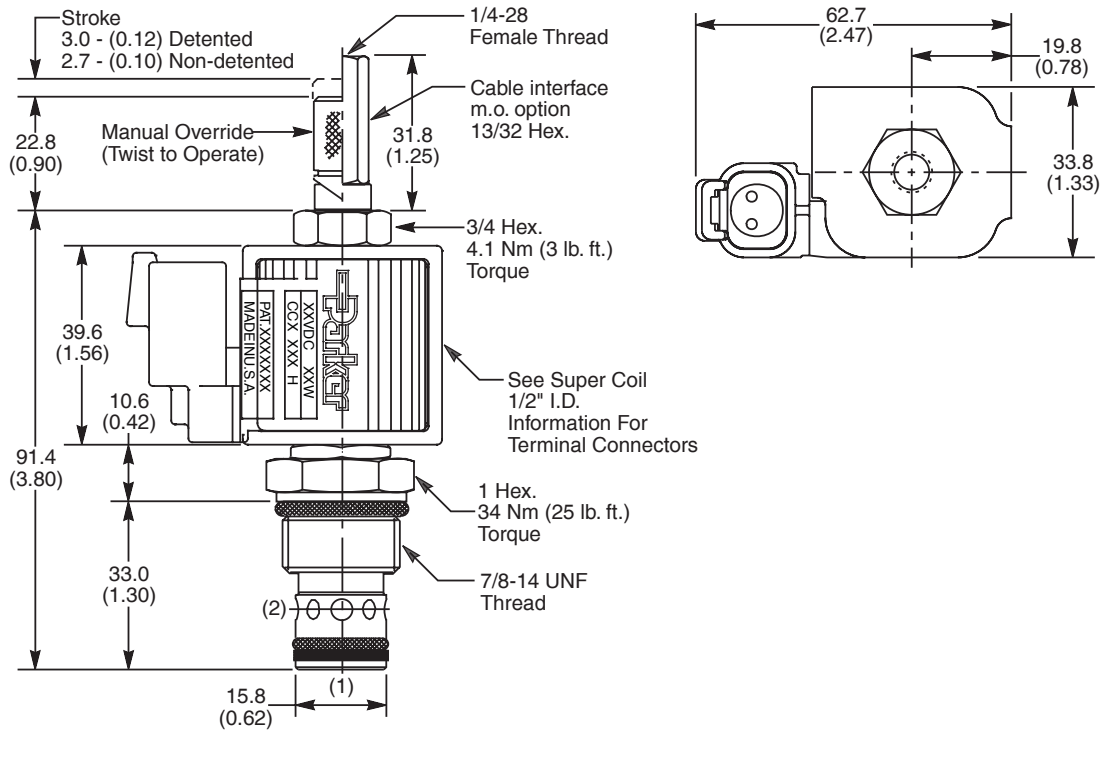

Ordering Information

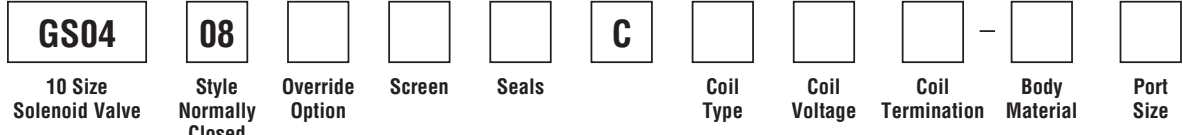

Code	Style
08	High Pressure, ("SP" Coil) Free Reverse Flow

Code	Seals / Kit No.
N	Nitrile / Buna-N (Std.) (SK30503N-1)
V	Fluorocarbon / (SK30503V-1)

Code	Coil Termination
Omit	Without Coil
C	Conduit With Leads
D	DIN Plug Face
A	Amp Jr. Timer*
S	Dual Spade*
W	Dual Screw*
L	Dual Lead Wire*
H	Molded Deutsch*

Code	Body Material
Omit	Steel
A	Aluminum

Code	Override Options
0	None
1	Detented
2	Non Detented
3	Cable Interface 210 Bar (3000 PSI)

Code	Coil Type
Omit	Without Coil
SP	Super Coil - 19 Watts

See Super Coil 1/2" I.D.
*DC Only

Code	Port Size	Body Part No.
Omit	Cartridge Only	
6T	SAE-6	(B10-2-*6T)
8T	SAE-8	(B10-2-*8T)
6B	3/8" BSPG	(B10-2-*6B)
8B	1/2" BSPG	(B10-2-*8B)

* Add "A" for aluminum, omit for steel.

Code	Screen
0	None

Code	Coil Voltage
Omit	Without Coil
D012	12 VDC
D024	24 VDC
A120	120 VAC, 60/50 Hz
A240	240 VAC, 60/50 Hz*

*22 Watts

- CV Check Valves
- SH Shuttle Valves
- LM Load/Motor Controls
- FC Flow Controls
- PC Pressure Controls
- LE Logic Elements
- DC Directional Controls
- MV Manual Valves
- SV Solenoid Valves
- PV Proportional Valves
- CE Coils & Electronics
- BC Bodies & Cavities
- TD Technical Data

